

# Rosemount™ Clarity II T56 Turbidimeter

## Turbidity Measurement System



- Complete system includes single or dual input transmitter, sensor(s), and debubbler assembly
- Resolution 0.001 NTU
- Easy to use transmitter with four analog outputs and four programmable alarm relays
- Intuitive, user-friendly menu in nine languages makes setup and calibration easy
- HART® digital communications standard
- Data and event logger stores thirty days of data for output on USB 2.0 memory stick

## Features and applications

The Rosemount T56 Turbidimeter is intended for the determination of turbidity in water. Low stray light, high stability, efficient bubble rejection, and a display resolution of 0.001 NTU make the turbidimeter ideal for monitoring the turbidity of filtered drinking water. You can also use the turbidimeter in applications other than drinking water treatment. Examples are monitoring wastewater discharges, condensate returns, and clarifiers.

The turbidimeter consists of a transmitter, which accepts either one or two sensors, the sensors themselves, and a debubbler/ measuring chamber and cable for each sensor. The cable plugs into the sensor and the transmitter, making setup fast and easy. Sensors can be located as far as 50 ft. (15.2 m) away from the transmitter.

- Choose US EPA 180.1 or ISO 7027 compliant sensors.
- ISO 7027 sensors use a near infrared light-emitting diode (LED).
- The turbidimeter incorporates the popular and easy to use Rosemount 56 Transmitter.
- 4-20 mA analog outputs are fully scalable.
- Every unit includes four alarm relays with interval timer functions. Alarms are fully programmable for high/low logic and dead band.

The turbidimeter is available in an optional configuration in which the transmitter, sensor(s), and debubbling flow cell(s) are mounted on a single back plate. The sensor cables are pre-wired to the transmitter, so setup is exceptionally fast and easy. Simply mount the turbidimeter on a wall, bring in power and sample, and provide a drain. To order this option, consult the factory.

---

### Contents

Features and applications.....	2
Ordering information.....	3
Specifications.....	5
Dimensional drawings.....	10
Accessories.....	13
Calibration standards.....	13

## Ordering information



[VIEW PRODUCT >](#)

- The Rosemount Clarity II Turbidimeter is a complete system for the determination of turbidity in water.
- It consists of an analyzer and one or two sensors with a debubbler/measuring chamber assembly and a cable for each sensor.
- Four alarm relays are standard.
- A calibration cup is available as an option.
- Because a sensor cannot be calibrated without a calibration cup, order at least one cup.
- Calibration standard (formazin or polymer spheres) must be ordered as a separate item.

### Sensor

Code	Description
01	EPA sensor
40	Two EPA sensors
02	ISO sensor
41	Two ISO sensors

### Measuring chamber

Code	Description
10	Debubbler flow chamber
60	Two debubbler flow chambers

### Sensor cable

Code	Description
20	20 ft. (6.1 m) cable
21	50 ft. (15.2 m) cable
50	Two 20 ft. (6.1 m) cables
51	Two 50 ft. (15.2 m) cables

Code	Description
23	One 20 ft. (6.1 m) cable, one 50-ft. (15.2 m) cable

## Instrument

Code	Description
30	Single input/HART® turbidity instrument (56-03-27-38-HT)
31	Dual input/HART turbidity instrument (56-03-27-37-HT)

## Calibration cup

Code	Description
71	Calibration cup (recommended for calibration)



# Specifications

## Note

Specifications subject to change without notice.

## General specifications

<b>Enclosure</b>	Polycarbonate. Type 4X/CSA 4X IP66
<b>Dimensions</b>	6.2 x 6.2 x 5.2-in. (157 x 157 x 132 mm)
<b>Conduit openings</b>	Accepts ½-in. or PG 13.5 conduit fittings.
<b>Display</b>	Large 3.76 x 2.2-in. (95.3 x 55.9 mm) high resolution color LCD display for large process variables and user-definable display of diagnostic parameters. Back-lighting is user adjustable. You can customize the main display to meet your requirements.
<b>Measurement character height</b>	0.5-in. (13 mm)
<b>Security code</b>	Three-digit code prevents accidental or unauthorized changes in instrument settings and calibration.
<b>Languages</b>	<ul style="list-style-type: none"> <li>■ English</li> <li>■ French</li> <li>■ German</li> <li>■ Italian</li> <li>■ Spanish</li> <li>■ Portuguese</li> <li>■ Chinese</li> <li>■ Russian</li> <li>■ Polish</li> </ul>
<b>Units</b>	Turbidity <ul style="list-style-type: none"> <li>■ NTU</li> <li>■ FTU</li> <li>■ FNU</li> </ul> Total suspended solids <ul style="list-style-type: none"> <li>■ mg/L</li> <li>■ ppm</li> <li>■ No units</li> </ul>
<b>Display resolution: turbidity</b>	Four digits; decimal point moves from x . xxx to xxx . x
<b>Display resolution: TSS</b>	Four digits; decimal point moves from x . xxx to xxx . x
<b>Calibration methods</b>	User-prepared standard, commercially prepared standard, or grab sample. For total suspended solids, you must provide a linear calibration equation.
<b>Ambient temperature and humidity</b>	32 to 131 °F (0 to 55 °C)

<b>Altitude</b>	For use up to 6562 ft. (2000 m).
<b>Storage temperature</b>	-4 to 140 °F (-20 to 60 °C)
<b>Real time clock backup</b>	24 hours
<b>Power</b>	85 to 265 Vac, 47.5 to 65.0 Hz, 20 W min. input power Equipment protected by double insulation.
<b>Inputs</b>	One or two isolated sensor inputs.
<b>Outputs</b>	Four 4-20 mA or 0-20 mA isolated current outputs. Fully scalable. Maximum load: 550 ohm. Output 1 has superimposed HART® signal.
<b>Output dampening</b>	0-999 seconds
<b>Current output accuracy</b>	±0.05 mA at 77 °F (25 °C)
<b>Alarms</b>	Four process alarm relays for turbidity or temperature. You can also program relays for timer, TPC, or fault alarm operation instead of as process alarms. You can configure each relay independently. Alarm logic (high or low activation) and deadband are user-programmable.
<b>Terminal connections rating</b>	Power connector (3 leads): 24-12 AWG wire size. Signal board terminal blocks: 26-16 AWG wire size. Current output connectors (2 leads): 24-16 AWG wire size. Alarm relay terminal blocks: 24-12 AWG wire size.
<b>RFI/EMI</b>	EN 61326 
<b>LVD</b>	EN-61010-1 
<b>Relays</b>	Form C, single pole, double throw, epoxy sealed

**Table 1: Maximum Relay Current**

Supply voltage	Resistive
28 Vdc 5.0 A	5.0 A
115 Vac 5.0 A	5.0 A
230 Vac 5.0 A	5.0 A

**Field wiring terminals** Removable terminal blocks for power, analog outputs, and sensors.

**Transmitter hazardous location approvals**

**CSA approvals**



Class 1, Division 2, Groups A, B, C, and D  
Class II, Division 2, Groups E, F, and G  
Class III T4A Tamb = 50 °C

Evaluated to the ANS/UL standards. The C and US indicators adjacent to the CSA mark signify that the product has been evaluated to the applicable CSA and ANSI/UL standards for use in Canada and the US respectively.

**FM approvals**



Class I, Division 2, Groups A, B, C, and D  
Class II, Division 2, Groups E, F, and G

T4 Tamb = -10 °C to 60 °C

## Sensor

<b>Method</b>	EPA 180.1 or ISO 7027 (using 860 nm LED source). Must be specified when ordering.
<b>Incandescent lamp life</b>	One year (EPA 180.1)
<b>LED life</b>	Three years (ISO 7027)
<b>Wetted materials</b>	Delrin <sup>®</sup> , glass, EPDM
<b>Accuracy after calibration at 20.0 NTU</b>	0 - 1 NTU: ±2 percent of reading or ±0.015 NTU, whichever is greater. 0 - 20 NTU: ±2 percent of reading

---

### Note

The sensor can measure turbidity values of 2-200 NTU, but frequent cleaning may be required to maintain turbidity measurements.

---

<b>Cable</b>	20 ft. (6.1 m) or 50 ft. (15.2 m). Connector is IP65.
<b>Maximum pressure</b>	30 psig (308 kPa abs)
<b>Temperature</b>	40 to 95 °F (5 to 35 °C)
<b>Sensor body rating</b>	IP65 when cable is connected.

## Debubbler and flow chamber

<b>Dimensions</b>	18.1 x 4.1-in. (460 mm x 104 mm) diagram (approximately)
<b>Wetted materials</b>	ABS, EPDM, Delrin <sup>®</sup> , polypropylene, nylon
<b>Inlet</b>	Compression fitting accepts ¼-in. OD tubing; fitting can be removed to provide ¼-in. female national pipe thread (FNPT).
<b>Drain</b>	Barbed fitting accepts ⅜-in. ID tubing; fitting can be removed to provide ¼-in. FNPT. Must drain to atmosphere.
<b>Sample temperature</b>	40 to 95 °F (5 to 35 °C)
<b>Minimum inlet pressure</b>	3.5 psig 3.5 psig will provide about 0.01 oz./min (250 mL/min) sample flow.
<b>Maximum inlet pressure</b>	30 psig. Do not block drain tube.
<b>Recommended sample flow</b>	0.01 to 0.03 oz./min (250 to 750 mL/min)

## Miscellaneous

### Weight/shipping weight

---

#### Note

Rounded to the nearest lb. or 0.5 kg.

---

<b>Sensor</b>	1 lb./2 lb. (0.5 kg/1.0 kg)
<b>Transmitter</b>	2 lb./3 lb. (1.0 kg/1.5 kg)

**Debubbler** 3 lb./4 lb. (1.5 kg/2.0 kg)

## Sample engineering specification for Rosemount Clarity II Turbidimeter

### Turbidimeter

1. The turbidimeter shall be a complete system consisting of sensor, analyzer, flow chamber/debubbler, and interconnecting cable. The transmitter shall accept input from either one or two sensors.
2. The turbidimeter shall have the following accuracy (after calibration with 20.0 NTU standard): a) 0-5 NTU:  $\pm 2$  percent of reading or 0.015 NTU, whichever is greater; b) 0-20 NTU:  $\pm 2$  percent of reading.
3. The response time at 4 gph (250 mL/min) to 90 percent of final value following a step change shall be 4.5 minutes.
4. The sensor shall be constructed of corrosion-resistant Delrin<sup>®</sup> with glass lamp and detector windows.
5. Incandescent lamp life (USEPA-compliant sensor) shall be at least one year. Light-emitting diode (LED) life (ISO-compliant sensor) shall be at least three years.
6. The sensor shall include advanced diagnostics, which will continuously measure the lamp intensity and automatically adjust the lamp output thereby maintaining the correct lamp intensity, correct for lamp drifting and aging, and allow for longer sensor operation with reduced calibration requirements.
7. The measuring chamber shall be constructed of ABS and Delrin. A bubble removal section shall allow entrained bubbles to escape from the sample before measurement.
8. The turbidimeter shall accept a sample stream having temperature between 40 and 95 °F (5 and 35 °C) with inlet pressure as high as 30 psig with drain to open atmosphere.
9. The sample chamber shall include a two-stage removal of entrained bubbles and outgassed bubbles to prevent erroneous turbidity readings.

### Transmitter

1. The transmitter shall have a large back-lit display.
2. The transmitter shall measure turbidity in the range 0 to 5 NTU with a display resolution of 0.001 NTU. Display units shall be user selectable among NTU, FTU, and FNU.
3. The transmitter shall display menu items and prompts in a language selected by the user. The languages shall be English, German, French, Spanish, Italian, Portuguese, and Chinese.
4. The transmitter shall allow direct button key access to comprehensive diagnostics from the main display screen.
5. The transmitter shall allow the user to customize the readouts on the main display screen.
6. A user-defined security code shall be available to protect against accidental or unauthorized changes to program settings and calibration.
7. Bubble rejection, signal averaging, and output hold features shall be available.
8. The single input and dual input transmitters shall have two current outputs, and the dual input transmitter shall have dual output. User-selectable 0-20 mA and 4-20 mA outputs shall be provided. Outputs shall be isolated with 550 ohm maximum load.
9. Four relays are standard. All alarms shall be fully programmable for high/low logic and deadband. All alarms can be configurable as a fault alarms. Interval timers can be enabled.
10. Environmental limits for the transmitter shall be 32 to 122 °F (0 to 50 °C) and 10 to 90 percent relative humidity.
11. Interconnecting cable shall plug into the sensor and analyzer. Integral cable or cable with flying leads shall not be permitted. Maximum cable length shall be 50 ft. (15.2 m).
12. Field wiring terminal blocks for power, sensor, and analog outputs shall be removable for ease of wiring.



13. The transmitter enclosure shall be Type 4X/CSA 4 (IP65), and the power requirements shall be in the range of 85 – 265 Vac, 47.5 – 65.0 Hz or 2030 Vdc.
14. If so programmed, the transmitter shall convert measured turbidity to a total suspended solids (TSS) reading using a linear equation entered by the user. Units for TSS shall be user selectable among ppm, mg/L, or no units.
15. HART® digital communications shall be available as an ordering option.

**Calibration**

1. The transmitter shall offer three methods of calibration: two-point slope calibration with deionized water and diluted formazin, standard calibration to a commercial standard, and calibration to a grab sample measured on a reference turbidimeter.
2. A maximum of 300 mL of calibration standard shall be required to calibrate the transmitter.
3. Accessories, unless noted: Calibration cup, cal kits with formazin.

The Rosemount Clarity II Turbidimeter shall include a one year factory warranty.

The turbidimeter shall be Rosemount T56 Clarity II Turbidimeter or approved equal.

# Dimensional drawings

Figure 1: Panel Mount Dimensions

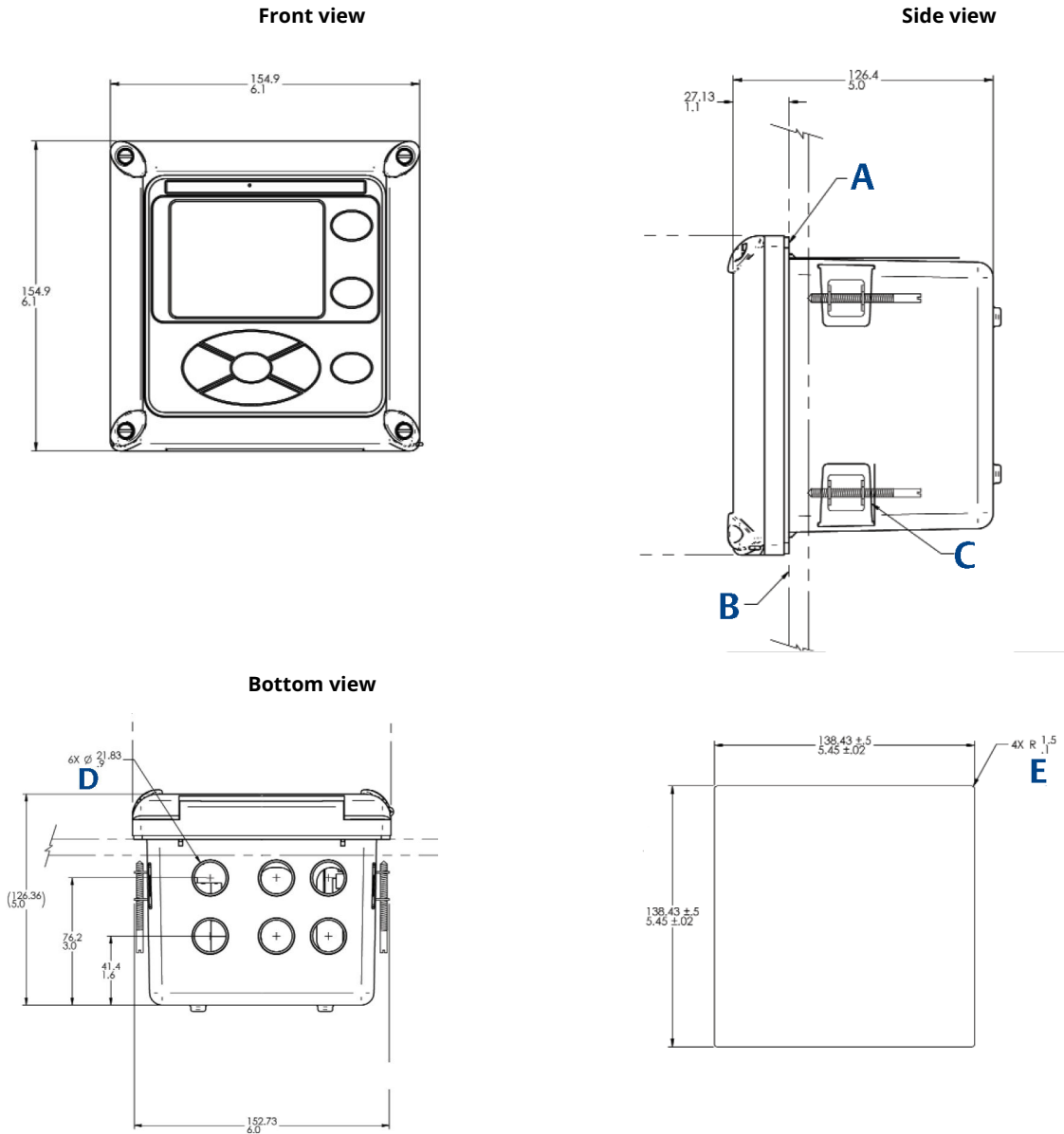

- A. Panel mount gasket
- B. Panel supplied by others maximum thickness 0.375 in. (9.52mm)
- C. Four mounting brackets and screws provided with instrument
- D. Conduit openings
- E. Maximum radius

**Note**

The front panel is hinged at the bottom. The panel swings down for easy access to the wiring locations.

**Figure 2: Pipe/Wall Mount Dimensions (Mounting bracket PN:2382000)**

**Wall/surface mount**

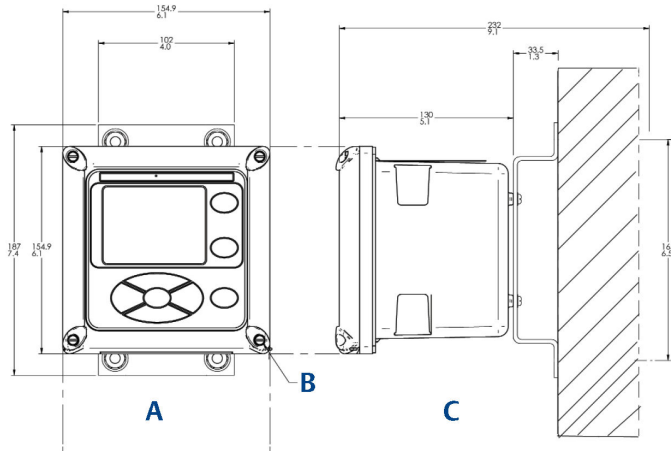

**Pipe mount**

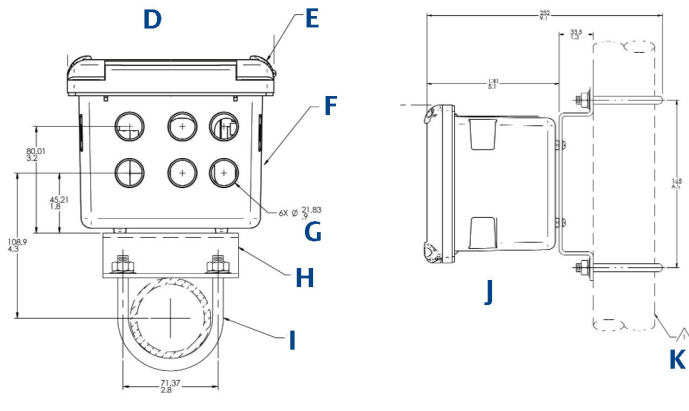

- A. Front view
- B. Four cover screw
- C. Side view
- D. Bottom view
- E. Front panel
- F. Panel and pipe mount enclosure
- G. Conduit openings
- H. 2-in. pipe mount bracket
- I. Two sets u-bolts for 2-in. pipe in kit PN 23820-00
- J. Side view
- K. 2-in. pipe supplied by customer

**Note**

The front panel is hinged at the bottom. The panel swings down for easy access to the wiring locations.

Figure 3: Sensor

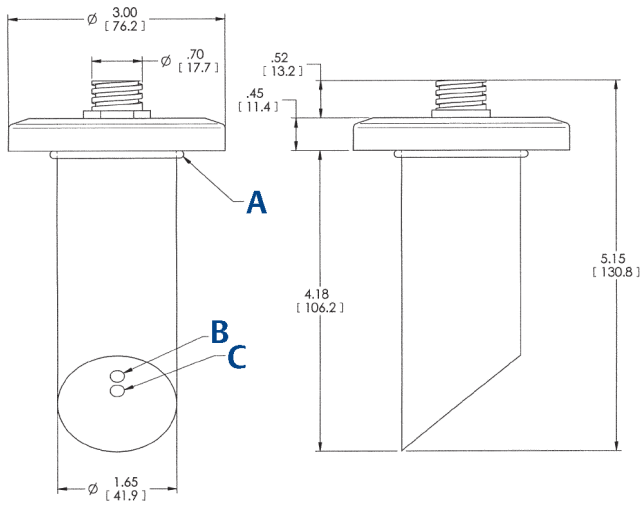

- A. O-ring PN 9550145
- B. Light source
- C. Detector

Figure 4: Debubbler and Flow Chamber

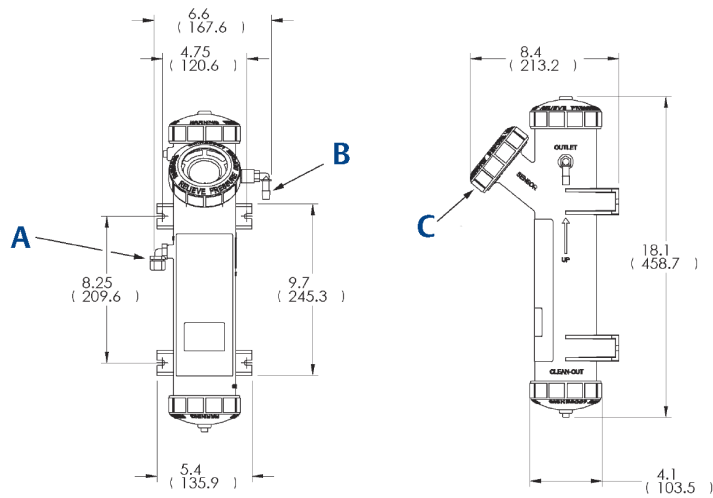

- A. Inlet
- B. Outlet
- C. Sensor port

## Accessories

Product number	Description	Weight	Shipping WT
23554-00	Cable gland kit for Model 54e, XMT, 1055, or 1056. Quantity 5	1 lb. (0.5 kg)	2 lb. (1.0 kg)
23820-00	Pipe mounting kit, includes u-bolts, mounting bracket, nuts, washers, and screws	2 lb. (1.0 kg)	4 lb. (2.0 kg)
23820-01	2-in. pipe mounting bracket, stainless steel	2 lb. (1.0 kg)	4 lb. (2.0 kg)
24101-00	Calibration cup	1 lb. (0.5 kg)	2 lb. (1.0 kg)
24138-00	Sensor cable, turbidity, 3 ft.	1 lb. (0.5 kg)	2 lb. (1.0 kg)
8-0108-0002-EPA	Replacement sensor, USEPA-compliant	1 lb. (0.5 kg)	2 lb. (1.0 kg)
8-0108-0003-ISO	Replacement sensor, ISO-compliant	1 lb. (0.5 kg)	2 lb. (1.0 kg)
24103-00	Flowmeter kit, includes valved rotameter and fittings	1 lb. (0.5 kg)	2 lb. (1.0 kg)
9240048-00	Tag, stainless steel, specify markings	0.1 lb. (0.05 kg)	1 lb. (0.5 kg)
9550145	O-ring for sensor, external, fits molded debubbler	0.1 lb. (0.05 kg)	1 lb. (0.5 kg)
24170-00	Molded debubbler with integral flow chamber	3 lb. (1.5 kg)	4 lb. (2.0 kg)
9550322	O-ring for upper and lower debubbler caps	0.1 lb. (0.05 kg)	1 lb. (0.5 kg)
1-901-0010-ISO	Replacement lamp board kit, ISO	0.1 lb. (0.05 kg)	1 lb. (0.5 kg)
1-0901-0009-EPA	Replacement lamp board kit, EPA	0.1 lb. (0.05 kg)	1 lb. (0.5 kg)

## Calibration standards

Product number	Description	Weight	Shipping WT
060-761855	Calibration kit (includes 4000 NTU formazin standard, pipet, pipet bulb, and volumetric flask)	1 lb. (0.5 kg)	2 lb. (1.0 kg)
905-761854	Formazin standard, 4000 NTU, 125 mL	1 lb. (0.5 kg)	1 lb. (0.5 kg)





For more information: [Emerson.com/global](https://emerson.com/global)

©2024 Emerson. All rights reserved.

The Emerson logo is a trademark and service mark of Emerson Electric Co. Rosemount is a mark of one of the Emerson family of companies. All other marks are the property of their respective owners.

**ROSEMOUNT™**

